

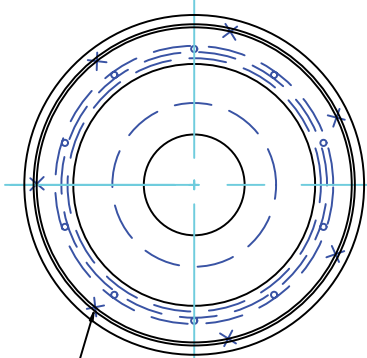

International Baghouse Supply

Cages

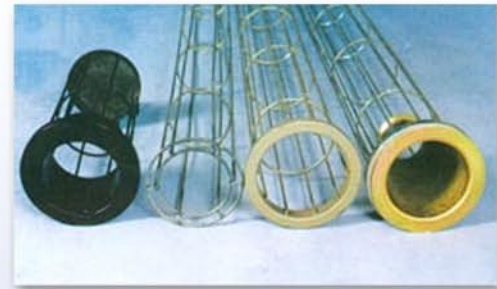

VENTURI & COLLAR
WELDED 5 PLACES,
72 DEGREES APART.

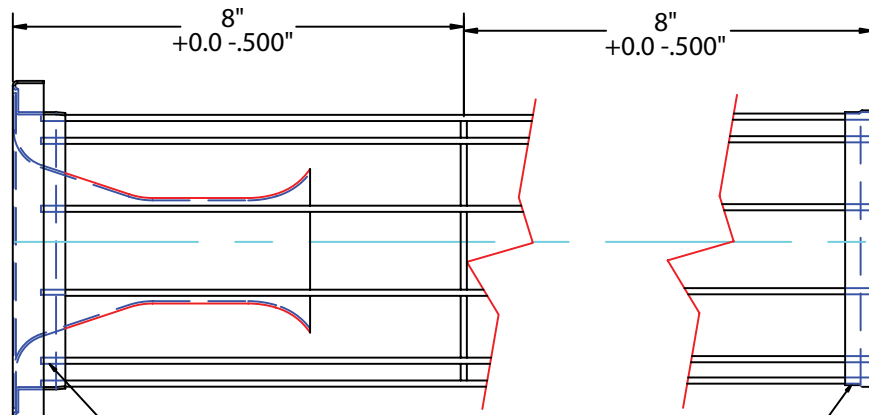

COLLAR WELDED 10 PLACES
TO VERT. CAGE WIRES

HEM CUP WELDED 10 PLACES

Construction			Materials / Finishes	
Top	Bottom	Wire		
Rolled Flange	Welded Pan	10	Carbon Steel	Zinc Coated
Split Rolled Collar	Crimped Pan	12	304 Stainless Steel	Epoxy Coated
Split Ring Collar	Wire Formed	20	306 Stainless Steel	
6" Venturi (Standard)		8 ga. Wire		
		6"-8" Ring Spacing		